

Volume 41 issue 416

June 2024

LAKE SHORE

**HOG**™

Monthly Newsletter



# What's Happening

**June 16, 2024**

**Social Gathering**

**Breakfast at 9 a.m.**

**Chapter business at 10 a.m.**

## **Upcoming Rides and Activities**

(check the calendar on the chapter website for details)

**Back Roads of Lake County WI (2nd try)**

Saturday, June 1st, 9:00 a.m.

**"On Any Sunday" Motorcycle Museum**

Sunday, June 2nd, 9:30 a.m.

**Top 10 Burgers #1—Twisted Burger**

Thursday, June 6th, 10:00 a.m.

**Saturday Breakfast & Beyond #1**

Saturday, June 8th, 8:00 a.m.

**LOH Artsy-Fartsy Ride**

Sunday, June 9th, 12:15 p.m.

**Top 10 Burgers #2—TBD**

Thursday, June 13th, 10:00 a.m.

**Let's Head to Psycho Silo**

Saturday, June 15th, 8:00 a.m.

# What's Happening

## Upcoming Rides and Activities

(check the calendar on the chapter website for details)

### **Father's Day Ride**

Sunday, June 16th, 11:00 a.m.

### **Top 10 Burgers #3—TBD**

Thursday, June 20th, 10:00 a.m.

### **Time for Starved Rock**

Saturday, June 22nd, 8:00 a.m.

### **The Devil's Run**

Sunday, June 23rd, 7:45 a.m.

### **Lake Shore H.O.G. ANNUAL GETAWAY**

St. Charles, MO

Thursday, June 27th—Sunday, June 30th

(see the flier on page 6)

### **WWDC #5—Honada Sushi & Hibachi**

Tuesday, July 30th, 6:45 p.m.



## Douglas Wrobel

### Director

Well, hello again. We had another great turnout for the May chapter gathering. I just hope that it stays that way. We are still getting new members from the City Limits and I would like to welcome them all.

The 34th Annual Bike blessing is in the books. All in all, I do believe that it went rather well. Everyone left Lake Shore Harley-Davidson and arrived at St. Paul's Church in a timely manner and in one piece. Again, I would like to THANK John Sweeney for all that he does to plan and to keep the Bike Blessing on track. Also, Roz Wrobel and her crew for getting all the waivers signed and wristbands to all the riders. And last but not least, all the flaggers who helped direct the riders to the church – a job well done. BRAVO ZULU to you all. It definitely is a whole chapter undertaking.

Don't forget about our Chapter Trip at the end of June. We will be at the Comfort Suites. The address for the Comfort Suites Inn is 1400 S Fifth Street, St Charles, Mo. It will be here before we know it. So I would like to meet up with everyone under the gazebo at Lamb's Farm right after our June gathering.

Our next gathering is on Father's Day. Lamb's Farm puts out a good spread for it. They will need our room because they will have reservation starting at 11:00. We need to be done with our business a little early so they can set up.

## Director (continued)

The following two rides are dealership-sponsored events. Both rides start and end at the dealership. There will be food trucks, music, and (I think) giveaways at both. If you can help out at either or both of these events, please let me know.

- Saturday, June 8<sup>th</sup>, at 9 a.m, in association with Angeles Del Silencio LE MC, is the 1st Ride to Resilience.
- Saturday, June 15<sup>th</sup>, at 9:30 a.m., in association with the Pinoy Cruisers, is a Memorial Ride for Joey Socorro.

So now, let's ride and have some fun. Don't forget about ride 365.



Doug Wrobel

**Director/Road Captain**

[director@lakeshorehog.com](mailto:director@lakeshorehog.com)



**LAKESHORE H.O.G. ANNUAL  
GET AWAY**

**THIS YEAR'S TRIP  
TAKES US DOWN TO  
ST CHARLES MO**

JUNE 27<sup>TH</sup> – JUNE 30

COMFORT SUITES

1400 S FIFTH ST

ST CHARLES MO.

<http://www.choicehotels.com/ires/en-US/html/ArrivalInfo?hotel=MO131&srp=LLAKES&pu=no>

COME JOIN US AS WE HEAD DOWN TO ST CHARLES MO AND  
RIDE SOME OF THE BACK ROADS OR JUST VISIT THE ST  
CHARLES HISTORIC DISTRICT.



## Scott Sears Assistant Director

Hello Lake Shore H.O.G.

Well, the bike blessing turned out to be successful even though we no longer have the Lake County Sheriff's Department leading us. They did however, block two intersections for us which was a great help.

Big thanks to all of the people who helped out as flaggers to guide the riders at each turn. I believe we had a total of 180 bikes, which is much lower than past years but, considering the changes we had to make, was still was a good turnout.

Just a reminder to everyone about the Great Lakes H.O.G. Rally in Chippewa Falls, WI, June 5th—9th. It's not too late to register for that event.

Also, our summer chapter trip to St. Charles, MO is at the end of June; June 27th—30th. These trips are always a good time, and a great way to spend time with other members of our chapter.

Stay safe and I'll see you at the June gathering.

Scott (Pooh Bear) Sears

**Assistant Director/Road Captain**

[asstdirector@lakeshorehog.com](mailto:asstdirector@lakeshorehog.com)

224. 707.2383



## Roz Wrobel

### Membership

Greetings from the Membership Corner!

Summer is here, well I think that it is here. Even with all the rain that we have had, our members have been out riding. I know that some of us have really been putting the miles on and have been to some pretty awesome places. Keep those miles coming.

There are so many things happening! Remember, the Chapter Trip is at the end of June and our annual picnic is in July. That is also our Teddy Bear Ride. (see the flyer on page 13).

At the beginning of May, we had our annual Bike Blessing. It was a little different from previous years, but we had 186 bikes and everyone made it to the church on time. I can not say enough about all the volunteers that helped get the waivers and wristbands on the bikes as they were coming in. Without you, I'm not sure where I would have been. Also, the road captains that made sure that we all were safe, and knew where our next turn was. But most of all, John Sweeney. There is not a big enough thank you for all the work that you put in for this event. So THANK YOU!!!!!!

We are 160 family members strong and we are growing. It is always nice to see new faces and get to meet new members. This month, we had 4 new members: Jennifer Kempe, Kristie Antosz, Bob Horcher, and Gregory Werner. If you see them on a ride, at an event, or at the dealership, please say hi. We also have 3 returning members and they are: Doug Johnston, Alex Ofer, and Tony Leitzow. Welcome home.

## Membership (continued)

As always, please remember to keep your National H.O.G. membership updated. If it should expire, your membership with the chapter becomes inactive until your national H.O.G. is current. You can easily renew your membership by logging on [www.hog.com](http://www.hog.com). I will also send an email (or text if no email) if it has expired. I check several times a month, please make sure that I have your current email address.





**LAKE SHORE H.O.G.**

**FAMILY PICNIC**

**SUNDAY, JULY 21, 2024**

**12:00 TO 4:00PM**

\$10 per member to reserve your spot

\$10 non-refundable fee for guests

\$5 for all members and guest under 10 years of age

Member \_\_\_\_\_

Member \_\_\_\_\_

Guest \_\_\_\_\_

Please sign up at June meeting or send by mail:

**Roz Wrobel**

811 Oakley Ave. Waukegan, IL 60085

No later than July 14, 2024

### **The Teddy Bear Ride**

10:am lineup at the dealership      10:30am kickstands up

12:00 noon arrives at Nippersink Forest Preserve (RT 120 in Round Lake) for the picnic

The ride and picnic are in lieu of our regular meeting at Lambs Farm

**REMEMBER TO BRING YOUR STUFFED ANIMALS AND/OR HOT WHEEL CARS  
TO GET YOUR PATCH FOR THE PICNIC**



John R. Sweeney Jr.  
Head Road Captain/ Webmaster

Howdy everyone,

All I can say is "**GREAT JOB LAKE SHORE H.O.G.**"

We had a big challenge this year for our Bike Blessing with no more police escort and we feared that this might be our last one. But with help of so many of our members (too many to list), signing in riders, selling rockers, blocking streets, parking bikes at the dealership and at the church, and new this year, flagging at intersections, you all made our blessing a success and guaranteed that we will be able to continue doing it for years to come. Thank you, thank you, THANK YOU!!! All of you did an awesome job. We could not have pulled this off without all of you.

We are full-on into riding season and our calendar is looking great. We have over 80 rides posted so far with more to come. There is a great variety of weekend rides and now we are seeing more and more weekday rides (day and evening), so you have no excuse. Pick a date and/or location that appeals to you and RIDE.

That is the main focus of our chapter. Meet new people, make new friends, spend more time with old friends, and go get some wind therapy...

## Head Road Captain/ Webmaster (continued)

Don't forget to periodically check-in at the dealer with your mileage, so you that you receive your points towards the rewards.

### **Points Awarded (each 500 points = \$5.00)**

1,000 = 1,000 points

2,500 = 2,500 points

5,000 = 2,500 points

7,500 = 2,500 points

10,000 = 2,500 points

15,000 = 5,000 points

If you reach 15,000 miles, you'll receive \$150. Not bad for just riding, which we do anyway. So, don't forget to check-in throughout the year and download the Harley app to track your progress and do the dealer check-ins.

Till next month...

**John R Sweeney Jr.**

"Remember, it's not the destination, it's the journey!"

**Head Road Captain & Webmaster**

[HeadRoadCaptain@lakeshorehog.com](mailto:HeadRoadCaptain@lakeshorehog.com)

(847) 651-4469 (Cell) — (847) 882-0187 (Home)



## Sammie Sweeney Ladies of Harley (LOH) Officer

Looking forward to our art glass class and the Artsy/Fartsy ride on June 9th. If you were unable to reserve a spot in the class, still come out for the beautiful ride that my chauffeur—I mean—road captain husband has planned. One to the class and another one after he drops me off.

I have a mini-golf tournament in the works and I'm planning a lunch ride later this summer. That is it for now, more to come later...

### **Food for thought:**

"Two wrongs don't make a right, but three right make a left."

Author Unknown

Till next time,  
Sammie Sweeney  
**LOH (Ladies of Harley) Officer**  
[loh@lakeshorehog.com](mailto:loh@lakeshorehog.com)



# Teddy Bear Corner

Just a reminder that we not only collect Teddy bears, stuffed animals and Hot Wheels, but we also accept underwear and socks for infants through teenager/young adult sizes.

Don't forget our upcoming Teddy Bear Ride and annual chapter picnic in July. Bring your bears or cars to get your free rocker.

Till next time,  
Sammie Sweeney  
**Teddy Bear Coordinator**  
[teddybears@lakeshorehog.com](mailto:teddybears@lakeshorehog.com)

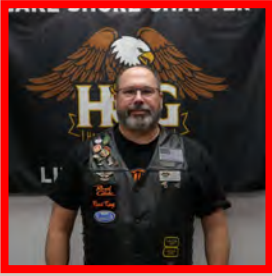

## Joe Murglin Safety Officer

It was great to see everyone at the gathering in May.

If you're still thinking of taking the Lock & Lean riding class let me know so I can put you on the list. We need at least 12 riders to reserve a class. See the link for more information [POLICE MOTORCYCLE TRAINING - ADVANCED MOTORCYCLE TRAINING - Police Motorcycle Training \(lockandlean.com\)](https://lockandlean.com)

I'm sure you've heard some of our older riders say, "When I'm not able to handle my Harley any longer, I'm gonna go out and buy a trike!" Well guess what. Based on what I found patented by Harley-Davidson, you could probably be using a walker and still ride your beloved Harley — and it's not automatic training wheels.

According to Patent 11577793, Gyroscopic Rider Assist Device, you won't have to worry about dropping your bike during slow speed maneuvers or when stopped at a light. The patent is for a gyroscope that's mounted either inside the tour pack or on the passenger pillion. The gyroscope will have sensors for speed and lean angle so it will know when to keep the bike vertical, and when to let it lean.

Hopefully, they'll have all the bugs worked out before they release it for production! I could just imagine seeing some old dude stop at a light and fall over like Benny Hill because of a software glitch! I guess one of the upsides could be that since the gyroscope could be hidden in the tour pack your friends will be amazed at your slow speed precision control.

# Safety Officer (continued)

Patent 11577793, Gyroscopic Rider Assist Device

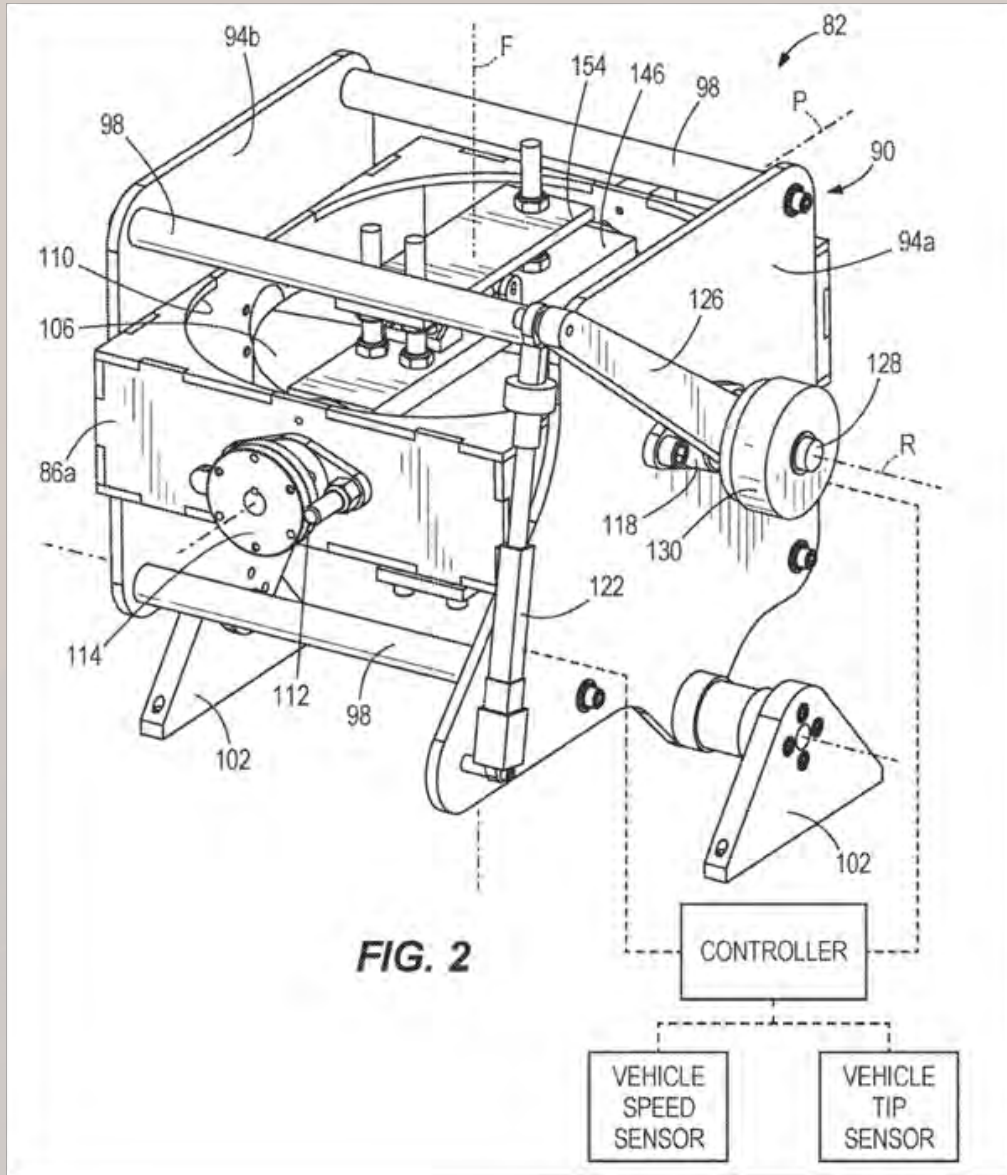



## Dave Jones Historian

### The First Recorded 100 MPH Harley-Davidson

The following is from March 1921 *Motorcyclist* magazine:

“The swiftly spinning wheels of the Harley-Davidson wrote unprecedented motorcycle history on the boards of the Fresno, (Cal.) one mile speedway on Washington’s birthday.”

*(My note: a one-mile-long oval board track! Imagine!)*

“They added the most brilliant paragraph to two-wheeled annals by exceeding 100 miles an hour in competition for the first time. Otto Walker literally tore mighty holes through the atmosphere and captured first in all four events. Walker, with his teammates, carried the Harley-Davidson colors to magnificent victory taking nine of twelve places and exceeding the world’s records for 1, 5, 10, and 50 miles!”

OK, back to me again. Four races with ‘Win, Place, and Show’ awards—and Harley-Davidson takes 9 of the possible 12 awards. Not too shabby!

## Historian (continued)

Results were recorded as follows:

One Mile:

Otto Walker H-D (33.4 seconds - 107.78 mph)

Albert Burns H-D (40.4 seconds - 104.65 mph)

Ten Miles:

When racing in the 10 miles race, Otto set the one mile record (noted above) and the 5 mile record @ 2:52.4, which is 104.5 mph over 5 miles.

15 miles:

Walker (again) (averaged 104.37 mph)

Ralph Hepburn and Fred Ludlow (both on H-D's) took second and third place at 15 miles, though no times/speeds were recorded.

50 Miles:

Walker - World Record time of 29:34.6 (averaged 101.43 mph)

Ludlow was recorded in second place.

Otto Walker rode a special Harley called the Banjo 2-Cam/8-valve Harley-Davidson engine for these records. The 2-cam design, fitted into the most up-to-date Harley frame at that time, was not available to the general public/regular customers. It had a beefed up crank case, the "banjo" shaped timing case, and 2 separate roller cam followers on which the tappets rode. These were an 'indirect-action' design, because of the intermediate step of the cam followers between tappets and cams. These parts were cast as a permanent part of the crank case.

## Historian (continued)

“Banjos” and “Kidney Beans” were not sold to the public; they were specifically for factory racers/riders. They were also loaned to dealers for use by their top flight riders.

Harley used the designation “FH” (discontinued in 1929) and the models were officially called, the FH', FHAC, and FHAD.

Until next time, ride safe!

Dave Jones - RC/Historian LS - H.O.G.



### **Historian**

Dave Jones

[Historian@LakeShoreHOG.com](mailto:Historian@LakeShoreHOG.com)

IT'S RIDE TIME!!

Saturday, June 8, 2024

Let's ride to breakfast, then to the Garden's in Rockford, and then, to lunch!

Our three-leg Saturday ride will start at the McDondalds in Volo. Kickstands up at 8:00 a.m. About an hour later, we will stop for breakfast at Kelley's Family Restaurant in Harvard, IL.

Following breakfast (approx. 10 a.m.), we will head west/northwest through southern Wisconsin and back into Illinois for our next stop at Anderson's Japanese Gardens in Rockford.

After visiting the gardens, when we get hungry for lunch, we will saddle up and head out to Genoa, IL for a late lunch and the completion of our tour.

It'll be a very fun-filled day, with an early morning start, great meals, and a pretty super garden visit! We hope you can join us for a grand day!!

Saturday, June 8, 2024 / 30+ miles (to start) / Dave J & Chris  
Level 2 ride for all three legs

Kickstands up 8 a.m. sharp; McD's in Volo / Corner Rts 12 & 120

Heading to: Kelley's Family Restaurant  
5420 US - 14, Harvard, IL 60033  
(815) 943-7558

Then to: Anderson Japanese Gardens  
318 Spring Creek Rd, Rockford, IL 61107  
(815) 229-9390

Finally to: Crusin' Genoa or Main Street Bar & Grill  
Genoa, IL 60135

Hope to see ya' all there!!



## Bob Morrison Photographer

Hello sisters and brothers,

Our 34<sup>th</sup> Annual Bike Blessing was a complete success.

Thank you to John Sweeney for all his work in making it happen this year; thank you to Doug Wrobel for leading the largest group ride ever by the Chapter; and thank you to the many members who took part in this year's bike blessing.

Here are some of the memories:



# Bike Blessing (continued):



# Bike Blessing (continued):



# Bike Blessing (continued):



Bike Blessing (continued):



# Bike Blessing (continued):

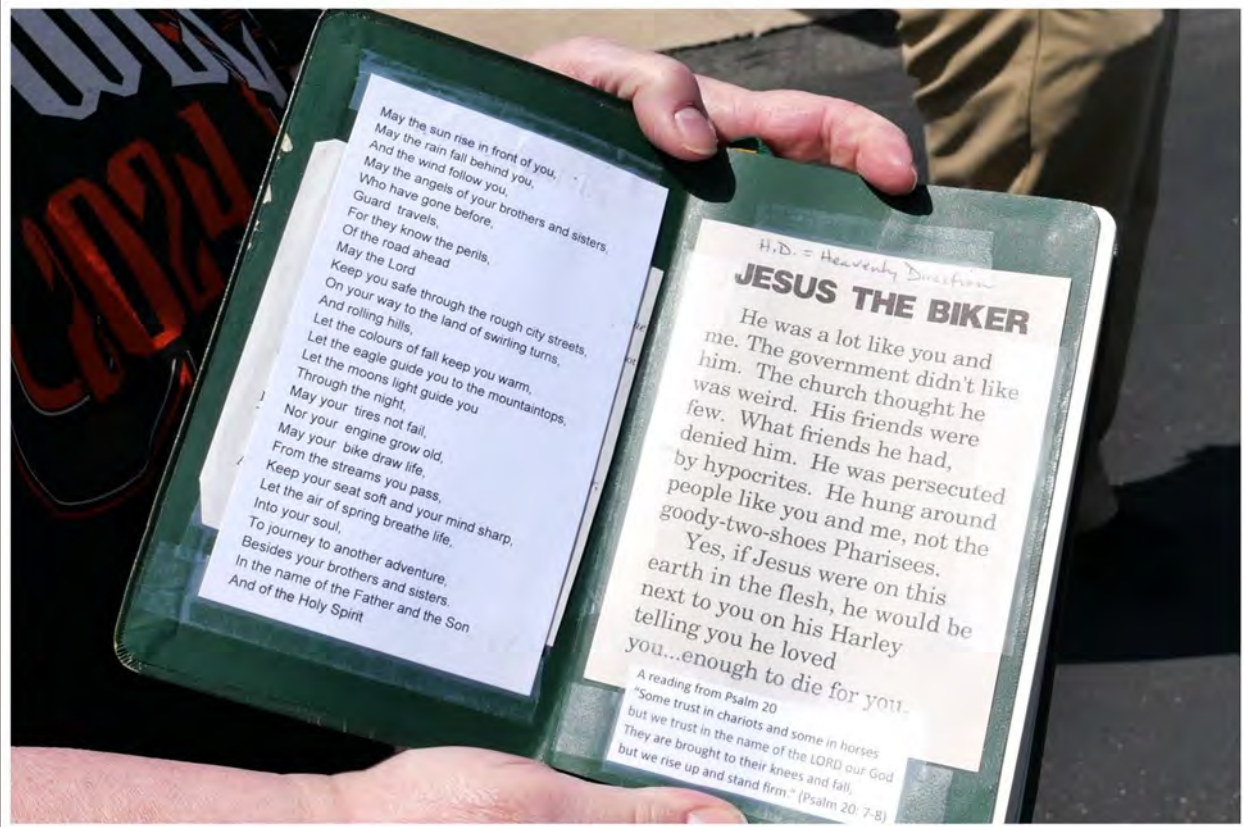

# Bike Blessing (continued):



# May 19th Gathering/Meeting:



# May 19th Gathering/Meeting (continued):



# Ride to Doyle



## Ride to Doyle (continued):



If any members post pictures of rides or events on our Facebook page, I will post them in the newsletter with your permission, and give you credit so others can see what our Chapter can offer.

Keep the rubber side down,

Bob Morrison

Bob Morrison

**Photographer**

[photographer@lakeshorehog.com](mailto:photographer@lakeshorehog.com)

## Primary Officers



**Director**  
Doug Wrobel  
224-627-3987  
[director@lakeshorehog.com](mailto:director@lakeshorehog.com)



**Treasurer**  
Richard (Rick) Cruz  
847-693-6527  
[treasurer@lakeshorehog.com](mailto:treasurer@lakeshorehog.com)



**Assistant Director**  
Scott Sears  
224-707-2383  
[assistantdirector@lakeshorehog.com](mailto:assistantdirector@lakeshorehog.com)



**Secretary**  
Colleen Hancock  
847-997-5542  
[secretary@lakeshorehog.com](mailto:secretary@lakeshorehog.com)

## Discretionary Officers



**Activities**  
To be advised  
[activities@lakeshorehog.com](mailto:activities@lakeshorehog.com)

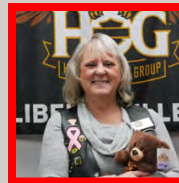

**Ladies of Harley**  
Sammie Sweeney  
[loh@lakeshorehog.com](mailto:loh@lakeshorehog.com)



**Historian**  
Dave Jones  
[Historian@LakeShoreHOG.com](mailto:Historian@LakeShoreHOG.com)



**Head Road Captain/Webmaster**  
John R (Motor Mouth) Sweeney Jr.  
[headroadcaptain@lakeshorehog.com](mailto:headroadcaptain@lakeshorehog.com)  
[webmaster@lakeshorehog.com](mailto:webmaster@lakeshorehog.com)



**Membership**  
Roz Wrobel  
[membership@lakeshorehog.com](mailto:membership@lakeshorehog.com)

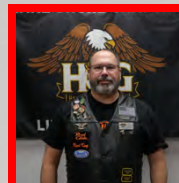

**Safety Officer**  
Joe Murglin  
[safety@lakeshorehog.com](mailto:safety@lakeshorehog.com)



**Photographer**  
Bob Morrison  
[photographer@lakeshorehog.com](mailto:photographer@lakeshorehog.com)



**Chapter Products**  
Nita Cruz  
[chapterproducts@lakeshorehog.com](mailto:chapterproducts@lakeshorehog.com)



**Editor**  
Denise Runge  
[editor@lakeshorehog.com](mailto:editor@lakeshorehog.com)

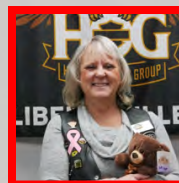

**Teddy Bears**  
Sammie Sweeney  
[teddybears@lakeshorehog.com](mailto:teddybears@lakeshorehog.com)